

Powering Business Worldwide

Table of Contents

Service Parts

Parts Identification	4
Exploded Assembly	5
Optional Assembly	6
Typical Cross Section	7
Drive Shaft	8
End Cover	9
Valve Plate	10
Housing	11
Rotating Groups	11
Shaft Seals	11
Compensator Kits - Factory Set	12
Mounting Screws	13
Plug Assemblies	13
Thru-Drive Couplings	13

Repair

420 Mobile Piston Pump Repair	14
General Information	15
Required Tools	15
Special Tools	15
Disassembly	16
Inspection, Repair and Part Replacement	23
Assembly	26
Testing	32
Assembly Torque Values	33

Part Identification - 420 Series Pumps

Item	Part Number	Quantity	Description	Page Number
1	See Table 1	1	Shaft, Drive ○	8
2	Not Saleable	1	Ring, Crush/Bearing Shim Kit 9900194-008 ○	25
3	See Table 1	1	Key, Drive Shaft	8
4	See Table 2	1	Endcover ○	9
6	16026-610	1	Roll Pin (Valve Plate)	5
8	See Table 3	1	Plate, Valve	10
10	16015-58-90	1	O-ring (End Pilot Cover)	5
12	16003-405-90	2	O-ring (End Cover/Housing)	5
14	See Table 4	1	Housing ○	11
16	4994698-001	1	Bearing Assy, Shaft (Front) ○	25
18	4994699-001	1	Bearing Assy, Shaft (Rear) ○	25
22	4993209-002	2	Bearing, Swashplate	5
23	4993411-050	2	Screw, Cap, Socket, Flat, CSK (Swash Bearing)	5
24	4993194-001	1	Spring, Bias	5
26	4997172-001	1	Swash Plate	5
28	See Table 5	1	Rotating Group S/A	11
30	16147-816	4	Screw, Cap (Housing/Endcover)	5
31	882993	1	VFO Drain Hole Filter (Double Shaft Seal)	6
32	See Table 6	1	Seal, Shaft ■	11
33	16077-32	1	Ring, Retaining, Internal (Shaft Seal)	5
34	16077-32	1	Ring, Retaining, Internal (Double Shaft Seal)	6
35	See Table 6	1	Seal, Shaft (Double Shaft Seal)	11
36	See Table 7	1	Compensator Kit	12
38	107275-011	2	O-ring (Compensator/Housing) ■	12
39	107275-017	1	O-ring (Secondary Compensator/Housing) ■	12
40	See Table 8	4	Screw, Cap (Compensator Mounting)	13
42	5993996-001	1	Piston, Control	5
44	See Page 6	1	Plug, Adjustable Volume Stop ▲	6
45	See Page 6	1	O-ring (Adjustable Volume Stop) ▲	6
46	See Page 6	1	Screw, Set (Adjustable Volume Stop) ▲	6
48	See Page 6	1	Nut, Sealing (Adjustable Volume Stop) ▲	6
50	16103-314	1	Plug Assy (Fixed Volume Stop)	5
52	16103-302	2	Plug (Endcover)	5
54	16103-302	1	Plug (Housing)	5
55	See Table 9	2	Plug (Diagnostic Ports)	13
56	See Table 9	1	Plug (Top Case Drain Port)	13
57	See Table 9	1	Plug (Bottom Case Drain Port)	13
58	937166	1	Cover, Tamper Proof (Compensator Adj. Screws)	5
80	See Table 10	1	Coupler	13
81	16008-000	1	Coupler Lock Ring	6
84	70142-600	1	Cover Plate, Aux. Mount	6
85	16007-14	1	O-ring, Cover Plate	6
86	16032-606	2	Screw, Cap (Cover Plate)	6

■ Standard Seal Kit: 9900633-000 Polyacrylate Shaft Seal Kit
 Optional Seal Kits: 9900634-000 Fluorocarbon Shaft Seal Kit
 9900634-001 Fluorocarbon Shaft Seal Kit C-Mount

▲ Adjustable Maximum Displacement Volume Stop Kit: 9900194-004

○ Bearing Shim Kit Required: 9900194-008

Exploded Assembly - 420 Series Pumps

Part Item Number

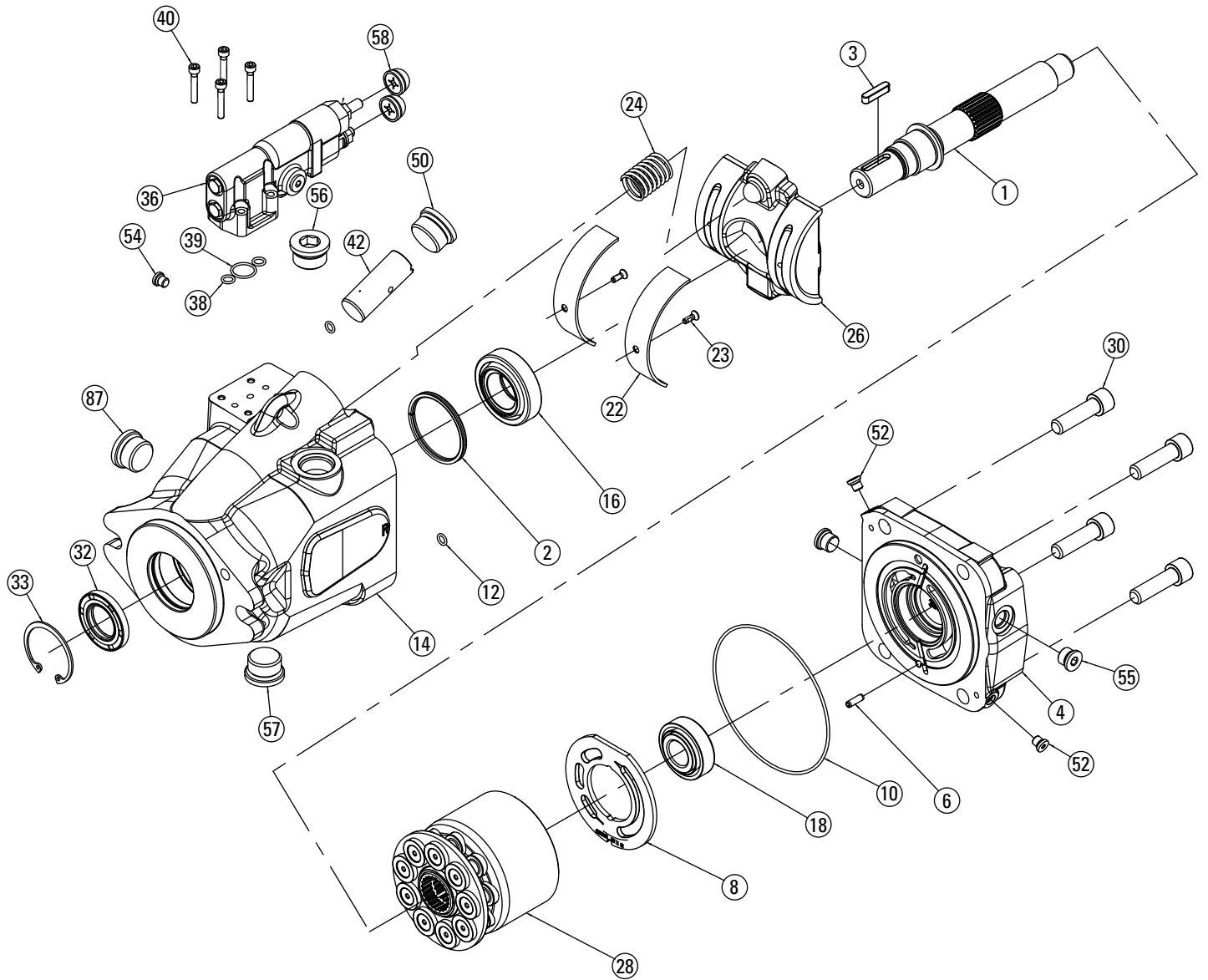

Optional Assembly - 420 Series Pumps

Part Item Number

Thru-Drive Part Option

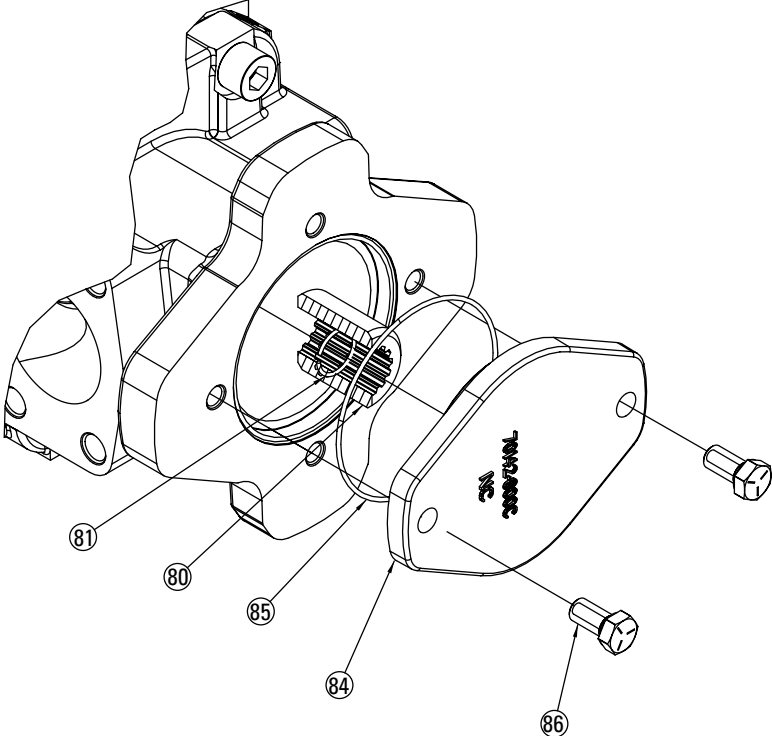

Dual Seal Option

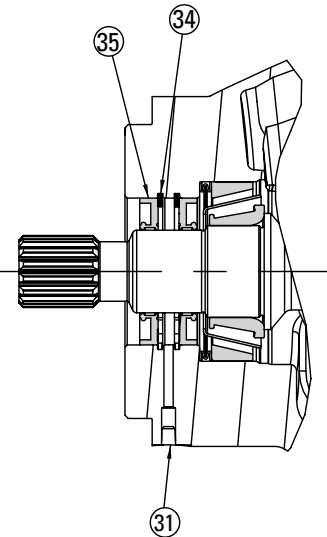

Adjustable Maximum Stop Option

(Replaces plug sub-assembly item
50-reference kit 9900194-004)

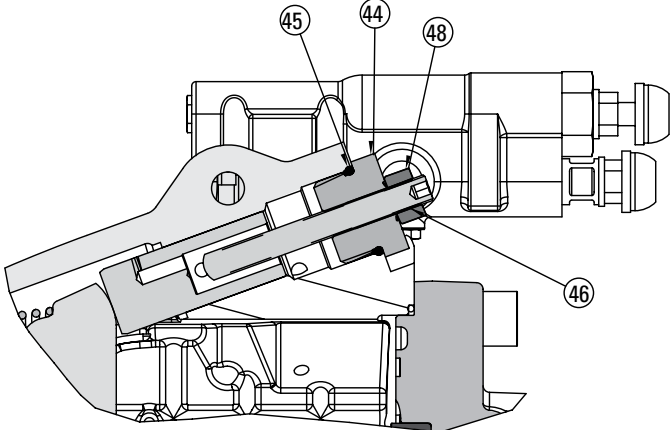

Typical Cross Section - 420 Series Pumps

Side View

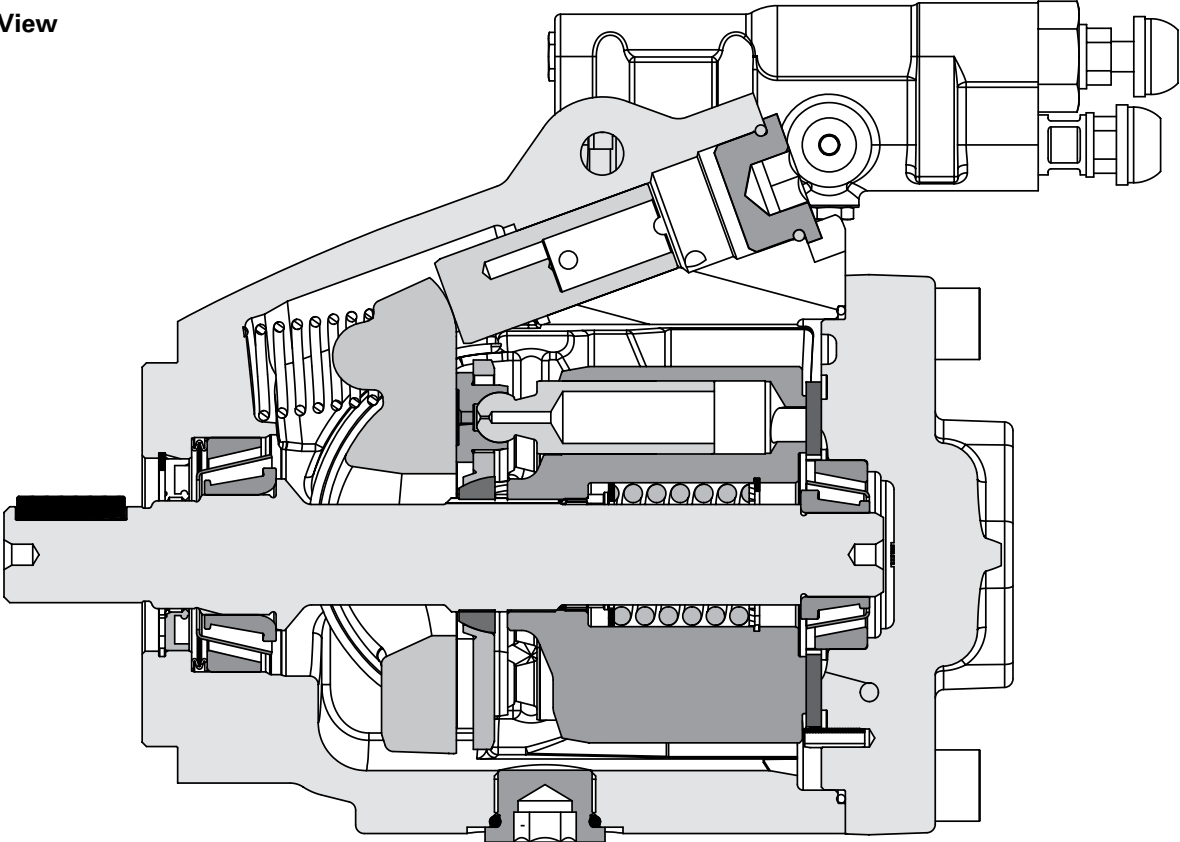

Drive Shaft - Item 1, 3

Table 1

Table 1 - Drive Shaft (Item 1)

Code Position 8,9	24,25	26	Key (Item 3)	Part Number	Description
01	00	0,1,2	24500-619	4997174-005	.875 Dia. w/Key, 1.62 Ext.
01	AA	0,1,2	24500-619	4997177-013	.875 Dia. w/Key, 1.62 Ext.
01	AB	0,1,2	24500-619	4997177-014	.875 Dia. w/Key, 1.62 Ext.
01	AC	0,1,2	24500-619	4997177-015	.875 Dia. w/Key, 1.62 Ext.
02	00	0,1,2	16246-516	4997174-004	1.00 Dia. w/Key, 1.81 Ext.
02	AA	0,1,2	16246-516	4997177-007	1.00 Dia. w/Key, 1.81 Ext.
02	AB	0,1,2	16246-516	4997177-008	1.00 Dia. w/Key, 1.81 Ext.
02	AC	0,1,2	16246-516	4997177-009	1.00 Dia. w/Key, 1.81 Ext.
04	00	0,1,2	20100-25	4997174-002	SAE J744- 25-3 Taper
04	AA	0,1,2	20100-25	4997177-002	SAE J744- 25-3 Taper
04	AB	0,1,2	20100-25	4997177-004	SAE J744- 25-3 Taper
04	AC	0,1,2	20100-25	4997177-003	SAE J744- 25-3 Taper
05	00	3	-	4995082-003	13 Tooth, 1.62 Ext. (Dual Seal)
05	00	0,1,2	-	4997174-003	13 Tooth 16/32, 1.62 Ext.
05	AA	0,1,2	-	4997177-010	13 Tooth
05	AB	0,1,2	-	4997177-011	13 Tooth 16/32, 1.62 Ext.
05	AC	0,1,2	-	4997177-012	13 Tooth 16/32, 1.62 Ext.
08	00	3	-	4995082-001	15 Tooth, 1.81 Ext. (Dual Seal)
08	00	0,1,2	-	4997174-001	15 Tooth 16/32, 1.81 Ext.
08	AA	0,1,2	-	4997177-005	15 Tooth 16/32, 1.81 Ext.
08	AB	0,1,2	-	4997177-006	15 Tooth 16/32, 1.81 Ext.
08	AC	0,1,2	-	4997177-001	15 Tooth 16/32, 1.81 Ext.
08	AC	3	-	4997596-001	15 Tooth, 1.81 Ext. (Dual Seal)
30	00	0,1,2	-	4997174-006	1.00 Taper W/.375-24 Thd.
30	AA	0,1,2	-	4997177-016	1.00 Taper W/.375-24 Thd.
30	AB	0,1,2	-	4997177-017	1.00 Taper W/.375-24 Thd.
30	AC	0,1,2	-	4997177-018	1.00 Taper W/.375-24 Thd.
31	00	0,1,2	16246-516	4997174-007	1.00 Dia. w/Key & .375 Thd.
32	00	3	-	4998581-001	14 Tooth 12/24, 2.18 Ext.

420 Series Mobile Piston Pump Drive Shaft

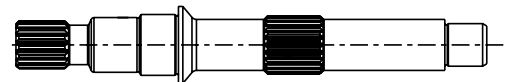

End Cover - Item 4

Table 2

Table 2 - End Cover (Item 4)

Code Position 4,5,6	10,11	13	24,25	Kit Number	Part Number	Description
041	AF	0	00	9900267-013	5992843-001	Endcover, Rear Port, SAE Threaded, 2.50
041	AF	0	00	9900267-014	5992847-001	Endcover, Side Port, SAE Threaded, 2.50
041	AF	0	AA	9900267-015	5992851-001	Endcover, Thru-Drive Dual A, SAE Threaded, 2.50
041	AF	0	AC	9900267-016	5992851-002	Endcover, Thru-Drive Dual B, SAE Threaded, 2.50
049	AB	0	AC	9900267-003	5992825-001	Endcover, Thru-Drive Dual B, Code 61, 3.00
049	AD	0	AC	9900267-004	5992825-002	Endcover, Thru-Drive Dual B, Code 61, 3.00 Metric
049	AB	3	00	9900267-007	5992831-001	Endcover, Side Port, Code 61, 3.00
049	AD	0	00	9900267-008	5992831-002	Endcover, Side Port, Code 61, 3.00 Metric
049	AA	0	00	9900267-009	5992837-001	Endcover, Rear Port, Code 61, 3.00
049	AC	0	00	9900267-010	5992837-002	Endcover, Rear Port, Code 61, 3.80 Metric
062/080	AB	0	AC	9900267-001	5992823-001	Endcover, Thru-Drive Dual B, Code 61, 3.80
062/080	AD	0	AC	9900267-002	5992823-002	Endcover, Thru-Drive Dual B, Code 61, 3.80 Metric
062/080	AB	0	00	9900267-005	5992829-001	Endcover, Side Port, Code 61, 3.80
062/080	AD	0	00	9900267-006	5992829-002	Endcover, Side Port, Code 61, 3.80 Metric
062/080	AA	0	00	9900267-011	5992839-001	Endcover, Rear Port, Code 61, 3.80
062/080	AC	0	00	9900267-012	5992839-002	Endcover, Rear Port, Code 61, 3.80 Metric

420 Series Mobile Piston Pump End Cover Views

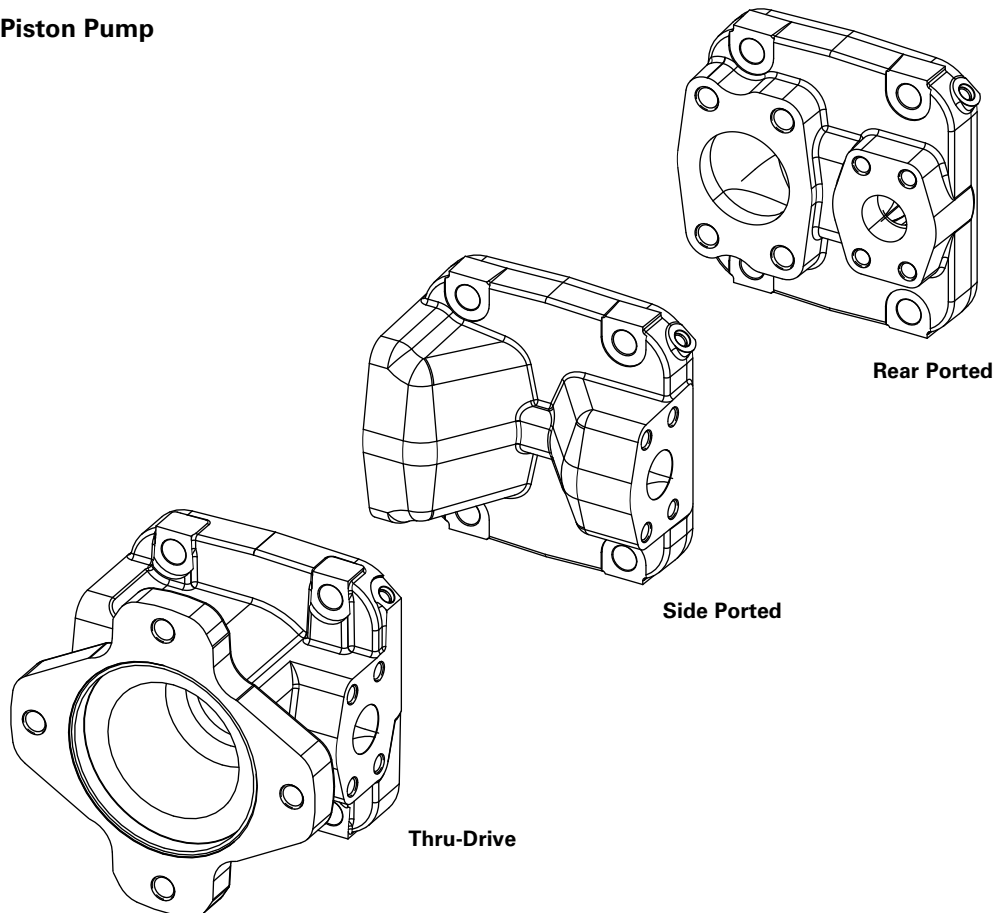

Valve Plate - Item 8

Table 3

Table 3 - Valve Plate (Item 8)

Code	Position	Part Number	Description
041	L	4997402-013	Plate, Valve 41cc (LH, 2.50)
041	R	4997403-013	Plate, Valve 41cc (RH, 2.50)
049	L	4995488-014	Plate, Valve 49cc (LH, 3.00)
049	R	4995489-014	Plate, Valve 49cc (RH, 3.00)
062	L	4995491-001	Plate, Valve 62cc (LH, 3.80)
062	R	4995492-001	Plate, Valve 62cc (RH, 3.80)
080	L	5986963-001	Plate, Valve 80cc (LH, 4.88)
080	R	4998319-001	Plate, Valve 80cc (RH, 4.88)

Valve Plate Identification

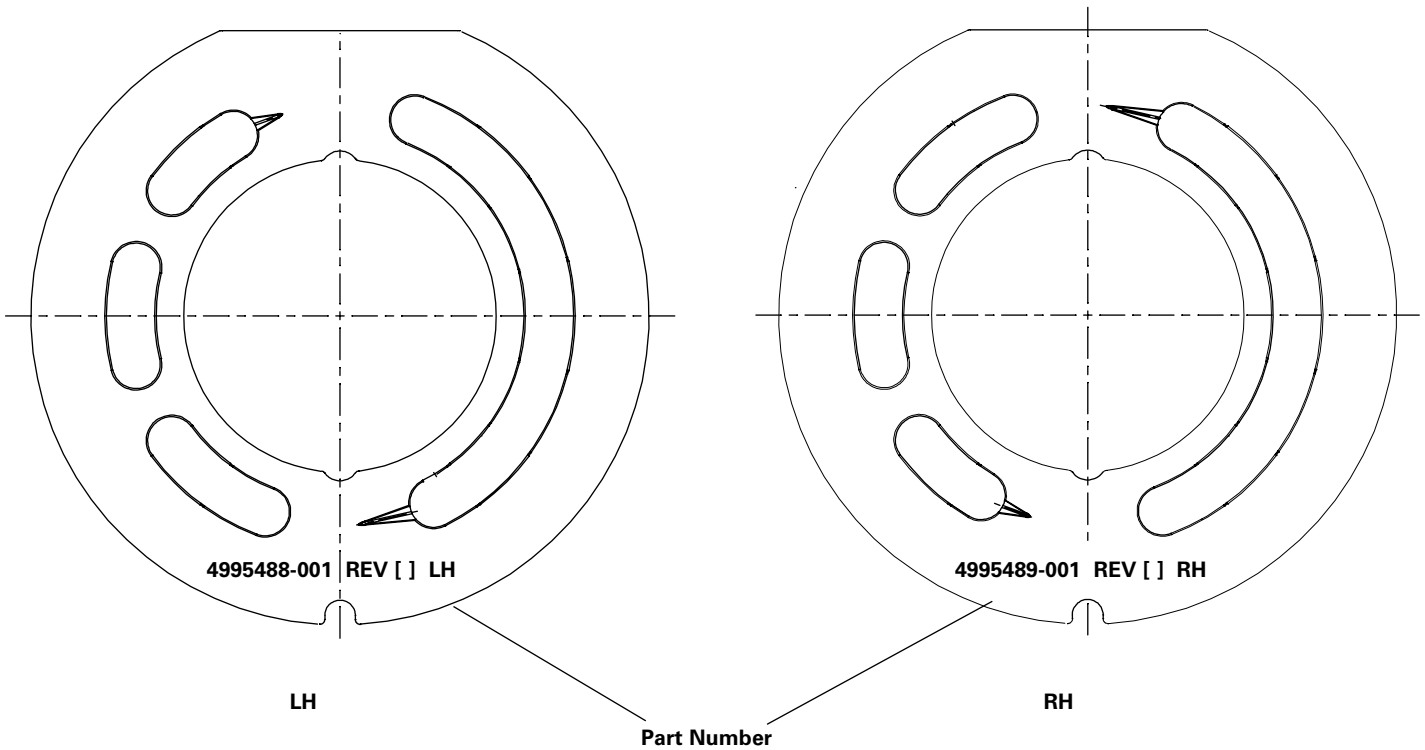

Housing - Item 14

Rotating Groups - Item 28

Shaft Seals - Item 32

Tables 4, 5 & 6

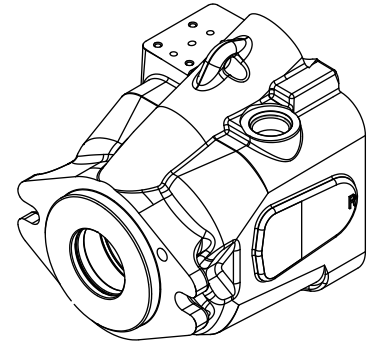

Table 4 - Housing (Item 14)

Code Position 8,9	12	26	27,28	Part Number	Description
not 32	1,2	3	not AB, AC	5999819-001	Housing (Double Seal)
not 32	3,4	3	not AB, AC	5999819-002	Housing (Double Seal, Metric)
not 32	1,2	3	AB	5999819-003	Housing (Double Seal, Swash Sensor)
not 32	1,2	not 3	not AB, AC	5999590-001	Housing
not 32	3,4	not 3	not AB, AC	5999590-002	Housing (Metric)
not 32	1,2	not 3	AB	5999590-003	Housing (Swash Sensor)
32	1,2	3	0	5999592-001	Housing (C Mount, Double Seal)
not 32	1,2	not 3	not AB, AC	5999591-001	Housing Torque Control
not 32	1,2	3	not AB, AC	5999593-001	Housing (C Mount, Double Seal) Torque Control

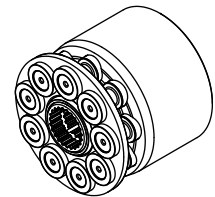

Table 5 - Rotating Group (Item 28)

Code Position 4,5,6	27,28	Part Number	Description
41	not AC	4993556-001	Rotating Group S/A 41cc (2.50 in ³)
49	not AC	4993463-001	Rotating Group S/A 49cc (3.00 in ³)
62	not AC	4993735-001	Rotating Group S/A 62cc (3.80 in ³)
80	not AC	4998046-001	Rotating Group S/A 80cc (4.88 in ³)

Table 6 - Shaft Seal (Item 32)

Code Position 8,9	26	Part Number	Description
Not 32	2 or 3	16253-218	Seal, Shaft, Fluorocarbon, SAE B
Not 32	1	4993012-001	Seal, Shaft, Polyacrylate, SAE B
32	3	4998834-001	Seal, Shaft, Fluorocarbon, SAE C Shaft
Not 32	4	16253-18	Seal, Shaft, Nitrile, SAE B



Compensator Kits - Item 36

Table 7 - Factory Set

Table 7 - Compensator (Pump Controls) (Item 36)

Control Code 14	Code 15,16	Pressure Limit Setting	Code 17,18	Flow Setting	Code 21,22	Kit Number
A	27	199.9-206.8 bar [2900-3000 lbf/in ²]	25	23.44-26.89 bar [340-390 lbf/in ²]	00	9900512-003
A	28	206.8-213.7 bar [3000-3100 lbf/in ²]	10	9.65-12.41 bar [140-180 lbf/in ²]	0A	9900512-013
A	28	206.8-213.7 bar [3000-3100 lbf/in ²]	14	12.41-15.17 bar [180-220 lbf/in ²]	00	9900512-022
A	28	206.8-213.7 bar [3000-3100 lbf/in ²]	14	12.41-15.17 bar [180-220 lbf/in ²]	0A	9900512-026
A	28	206.8-213.7 bar [3000-3100 lbf/in ²]	23	23.10-25.17 bar [335-365 lbf/in ²]	00	9900512-001
A	28	206.8-213.7 bar [3000-3100 lbf/in ²]	24	22.75-25.51 bar [330-370 lbf/in ²]	00	9900512-032
A	28	206.8-213.7 bar [3000-3100 lbf/in ²]	30	28.27-31.72 bar [410-460 lbf/in ²]	00	9900512-017
A	32	226.5-233.4 bar [3285-3385 lbf/in ²]	16	13.79-16.55 bar [200-240 lbf/in ²]	00	9900512-002
A	35	241.3-248.2 bar [3500-3600 lbf/in ²]	14	12.41-15.17 bar [180-220 lbf/in ²]	00	9900512-028
A	36	246.5-253.4 bar [3575-3675 lbf/in ²]	14	12.41-15.17 bar [180-220 lbf/in ²]	00	9900512-014
A	36	246.5-253.4 bar [3575-3675 lbf/in ²]	22	20.68-23.44 bar [300-340 lbf/in ²]	0A	9900512-031
A	40	262.0-268.9 bar [3800-3900 lbf/in ²]	14	12.41-15.17 bar [180-220 lbf/in ²]	0A	9900512-005
A	40	262.0-268.9 bar [3800-3900 lbf/in ²]	10	9.65-12.41 bar [140-180 lbf/in ²]	00	9900512-027
A	42	272.4-279.3 bar [3950-4050 lbf/in ²]	10	9.65-12.41 bar [140-180 lbf/in ²]	00	9900512-007
A	42	272.4-279.3 bar [3950-4050 lbf/in ²]	10	9.65-12.41 bar [140-180 lbf/in ²]	0A	9900512-006
A	43	275.8-282.7 bar [4000-4100 lbf/in ²]	14	12.41-15.17 bar [180-220 lbf/in ²]	00	9900512-010
A	43	275.8-282.7 bar [4000-4100 lbf/in ²]	14	12.41-15.17 bar [180-220 lbf/in ²]	0A	9900512-015
A	43	275.8-282.7 bar [4000-4100 lbf/in ²]	16	13.79-16.55 bar [200-240 lbf/in ²]	00	9900512-008
A	43	275.8-282.7 bar [4000-4100 lbf/in ²]	24	22.75-25.51 bar [330-370 lbf/in ²]	00	9900512-018
B	28	206.8-213.7 bar [3000-3100 lbf/in ²]	24	22.75-25.51 bar [330-370 lbf/in ²]	00	9900512-012
B	28	206.8-213.7 bar [3000-3100 lbf/in ²]	28	26.20-28.96 bar [380-420 lbf/in ²]	0A	9900512-019
B	43	275.8-282.7 bar [4000-4100 lbf/in ²]	24	22.75-25.51 bar [330-370 lbf/in ²]	00	9900512-011
C	12	137.9-144.8 bar [2000-2100 lbf/in ²]	00	No Flow Comp. Setting	00	9900512-021
C	19	168.9-175.8 bar [2450-2550 lbf/in ²]	00	No Flow Comp. Setting	00	9900512-023
C	21	179.3-186.2 bar [2600-2700 lbf/in ²]	00	No Flow Comp. Setting	00	9900512-029
C	28	206.8-213.7 bar [3000-3100 lbf/in ²]	00	No Flow Comp. Setting	00	9900512-016
C	43	275.8-282.7 bar [4000-4100 lbf/in ²]	00	No Flow Comp. Setting	00	9900512-009
C	45	306.8-313.7 bar [4450-4550 lbf/in ²]	00	No Flow Comp. Setting	00	9900512-004

Kit Contents

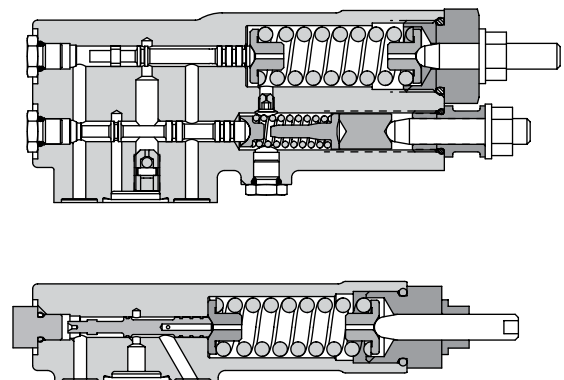
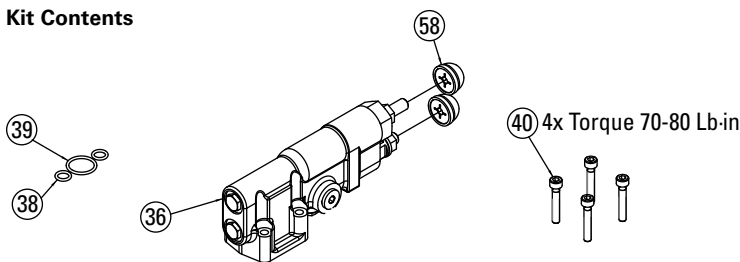

Mounting Screws - Item 40

Plug Assemblies - Items 55,56 & 57

Thru-Drive Couplings - Item 80

Tables 8, 9 & 10

Table 8 - Compensator Mounting Screw (Item 40)

Code Position 14	19,20	21,22	Part Number	Description
A,B,C	00	00,0A	114953-030	Screw, Cap (Compensator Mounting)

Table 9 - Plug Subassemblies (Items 55, 56, 57)

Code Position 10,11	12	13	Part Number	Description
Side Port	1,2	3	16103-304	Plug (Diagnostic Ports) .4375-20 Thd.
Rear Port	1,2	1	16103-306	Plug (Diagnostic Ports) .5625-18 Thd.
Side Port	3,4	4	9237-002	Plug (Diagnostic Ports) M12 x 1.5 Thd.
Rear Port	3,4	2	9237-003	Plug (Diagnostic Ports) M14 x 1.5 Thd.
-	2	1,3	16103-312	Plug (Top Case Drain Port) 1.0625-12 Thd.
-	4	2,4	9237-009	Plug (Top Case Drain Port) M27 x 2 Thd.
-	1	1,3	16103-312	Plug (Bottom Case Drain Port) 1.0625-12 Thd.
-	3	2,4	9237-005	Plug (Bottom Case Drain Port) M27 x 2 Thd.
-	6	0	9170-005	Plug (Bottom Case Drain Port) G 3/4 BSPP

Table 10 - Thru-Drive Couplings (Item 80)

Code Position 24,25	Part Number	Description
AB	70111-687	Coupler, 11 Tooth (SAE A)
AC	70411-638	Coupler S/A, 13 Tooth (SAE B)
AE	5987377-001	Coupler, 9 Tooth (SAE A)

420 Mobile Piston Pump Repair

Cutaway

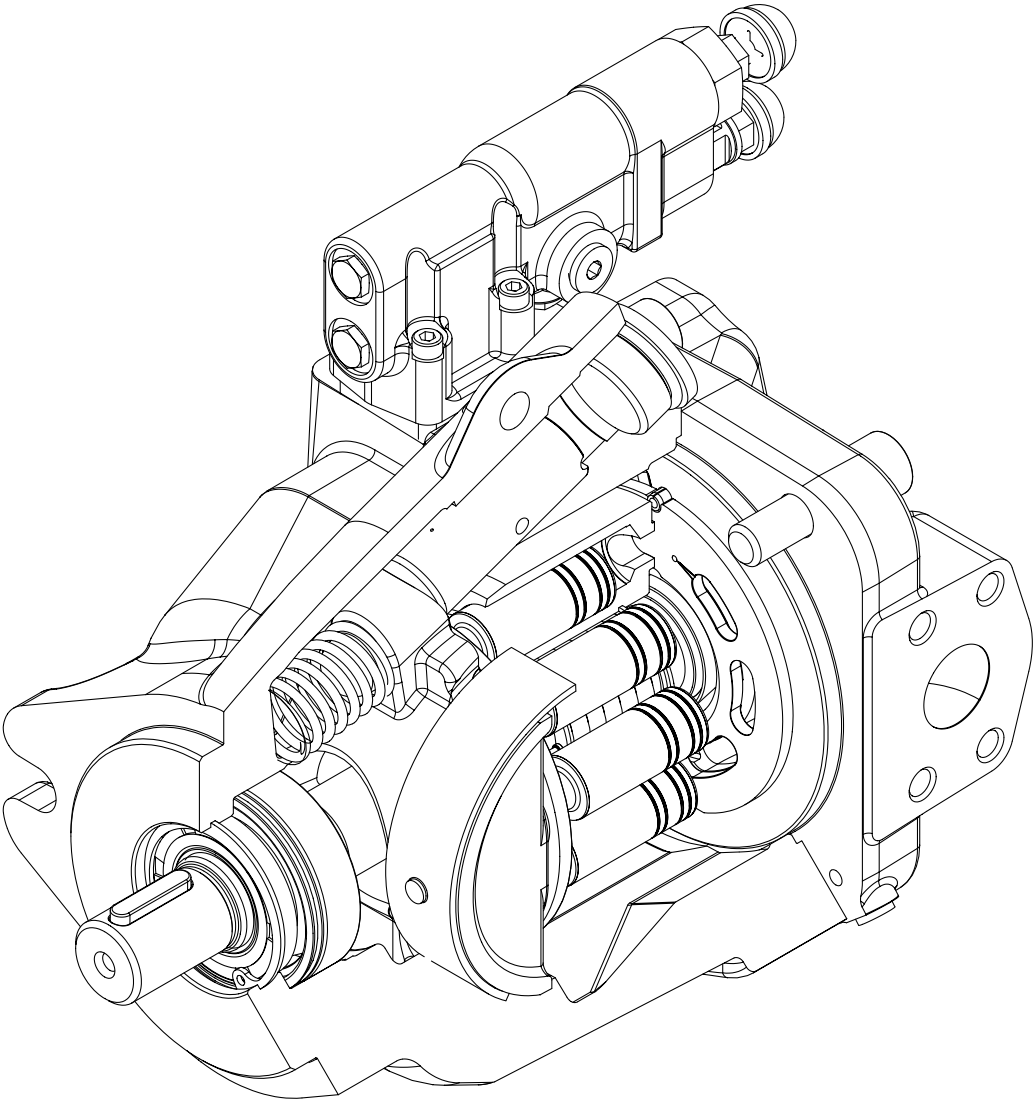

General Information

Ordering Replacement Parts

Replacement Parts

When ordering replacement parts, give the product number, date code, part name, part number and quantity of parts required. This product information is found stamped on the tag which is located on the side of the housing.

When the Eaton model 420 pressure, pressure-flow compensated piston pump is repaired, thoroughly clean the pump before any repairs are attempted.

The part number and serial number are on the tag.

Read this assembly manual thoroughly before starting work on the pump.

This manual assumes appropriately trained technicians with specialized knowledge of mechanical and hydraulic component assembly and disassembly.

Serial Number/Date Code Interpretation

08 02 17 RC 1010

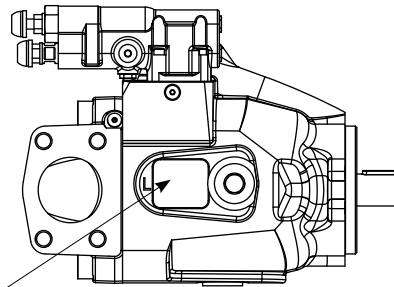
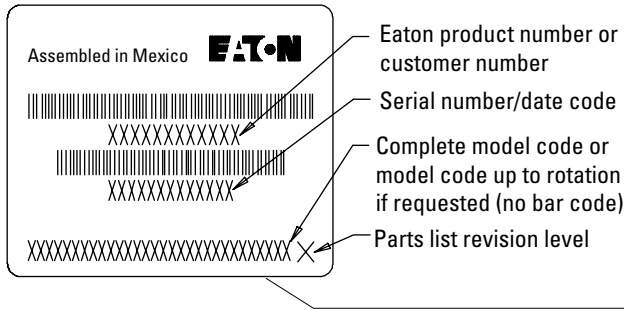
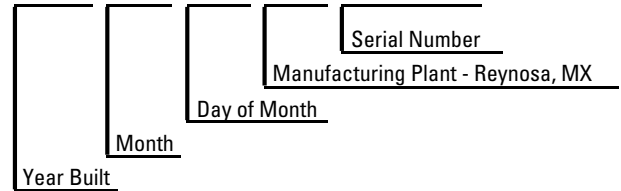

Required Tools

Standard Tools For Disassembly

- Ball Peen Hammer
- Plastic Tip Hammer
- Flat Tip Screw Driver
- Snap Ring Pliers
- Torque Wrench
- Magnet Stick
- 1-1/4" Wrench
- 1-3/8" Wrench
- 4mm Allen Wrench
- 3/32" Allen Wrench
- Impact Screwdriver
- Sliding Bearing Remover Hammer
- Dial Indicator and Accessories
- Marker or Paint Pen
- Petroleum Jelly
- Cleaning Solvent

Special Tools

- Assembly Tool Kit 9900275-000 (includes)

– Swashplate Locator Tool

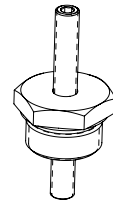

– Swashplate Retainer Tool

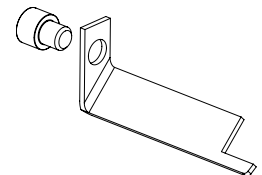

– Shaft Retainer Tool

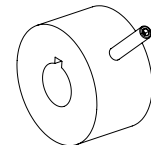

Disassembly

Before attempting to disassemble, clean the pump exterior. Dispose of leakage oil and oily cloths in an environmentally responsible manner. All parts within the unit must be kept clean during the overhaul

process. Handle each part with great care, marking as necessary to ensure proper reassembly. The close tolerance of the parts makes this requirement very important. Clean all parts that are removed from

the unit with a commercial solvent that is compatible with the system fluid. Compressed air may be used in the cleaning process. However, it must be filtered to remove water and other contamination.

1. Remove Control Piston Plug Assembly



2. Install Swash Plate Locator Tool



Note: Adjustment will take place in Step 11.

3. Remove Compensator



4. Remove End Cover

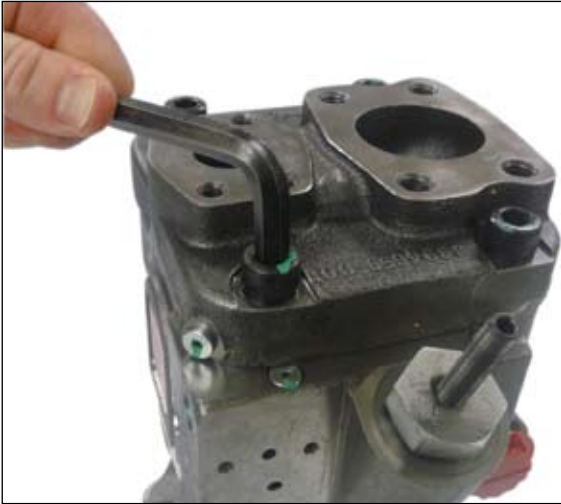

Note: The valve plate may stick to end cover. Use caution so valve plate does not fall off.

Mark the housing and end cover to ensure orientation. Remove the four cap screws that hold the end cover in place.

6. Remove O-ring Seal



5. Remove Valve Plate

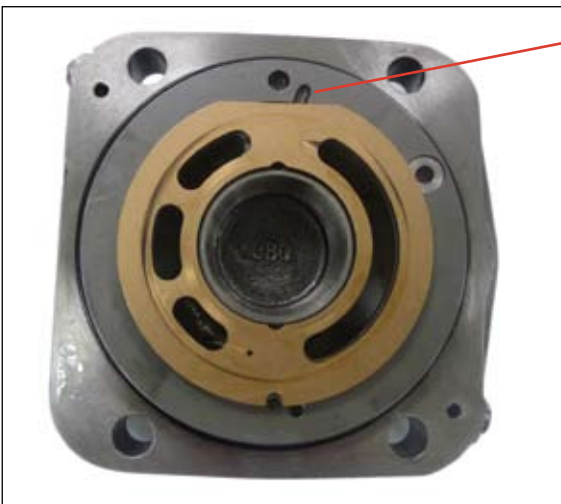

7. Remove Bearing Race



Note: The bearing race is pressed in and will require the use of a sliding bearing removal hammer or similar tool to remove it.

8. Remove Housing O-rings



10. Install Swashplate Retainer

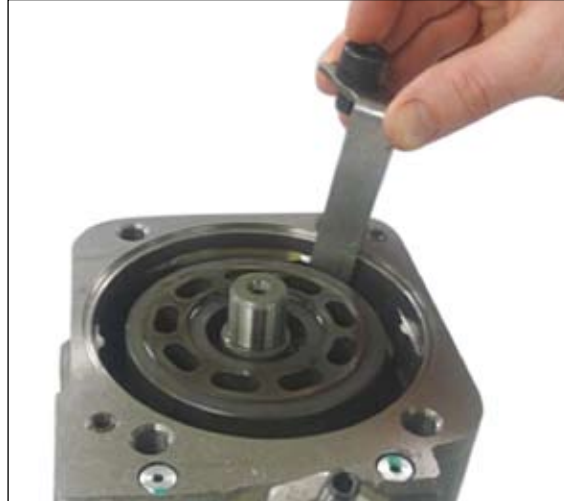

Note: Install the swash plate hold down tool and tighten the cap screw 16147-804. This will prevent the swash plate from moving.

9. Remove Bearing



11. Swashplate Locator Adjustment



Note: This step is designed to force the swashplate to a neutral position to enable easy removal of the rotating group, and to retain the swashplate.

With the hold down tool in place, tighten the adjustment screw so the control piston spring is compressed.

12. Install Shaft Retainer Tool



Note: Tighten the set screw while being careful not to damage shaft.

14. Remove Shaft



Note: Remove shaft retainer tool and lift out shaft. Use caution when moving shaft through shaft seal.

13. Remove Rotating Group



Note: Position shaft upwards and carefully remove rotating group.

15. Remove Swashplate Locator



16. Remove Swashplate Retainer



18. Remove Swashplate



17. Remove Control Piston



19. Remove Bias Spring



Note: The open end of the control piston is positioned up. The control piston is allowed to rotate.

20. Remove Bearing

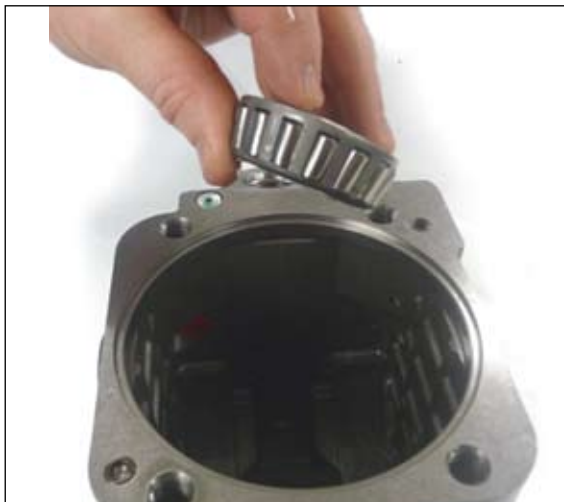

22. Remove Cradle Bearings



Note: The cradle bearings are asymmetrical. The proper orientation is shown.

21. Remove Cradle Bearing Screws



Caution: Socket head cap screws are easily damaged during repair with improper tool.

23. Remove Front Bearing Race



24. Remove Crush Ring



Note: The crush ring located under the bearing cup in the housing does not need to be removed. The only time the crush ring needs to be removed is when the front or rear shaft tapered roller bearings, bearing cups, drive shaft, end cover or housing assembly is replaced. A shim kit is required if the crush ring is replaced.

25. Remove Shaft Seal



Note: With the seal retaining ring removed use a punch or similar tool to knock out the shaft seal.



Inspection, Repair and Part Replacement

Inspection

Inspection

Before inspection of parts, clean with a solvent that is compatible with system fluid.

Rotating Group Parts

1. Inspect cylinder block face for wear, scratches, and/or erosion. If cylinder block condition is questionable, replace the entire rotating group.
2. Remove the pistons, shoe retainer, and pivot from piston block. The piston block assembly doesn't need to be disassembled unless the internal pins or spring are damaged.
3. Check each cylinder block bore for excessive wear. Use the piston and shoe S/A (37) for this purpose. The pistons should be a very close fit and slide in and out of the cylinder block bores. **NO BINDING CAN BE TOLERATED.** If binding occurs, clean the cylinder block and pistons. Lubricate the cylinder block bores with clean fluid and try again. Even minor contamination of the fluid may cause a piston to freeze up in a cylinder bore.
4. Inspect each of the nine piston and shoe subassemblies (31) for a maximum end play of 0.005 inch between the piston and shoe. Also check the face dimension of each shoe. The face dimension must be within 0.001 inch.
5. Inspect shoe retainer and pivot for wear and/or scratches. If condition is questionable, replace entire rotating group.

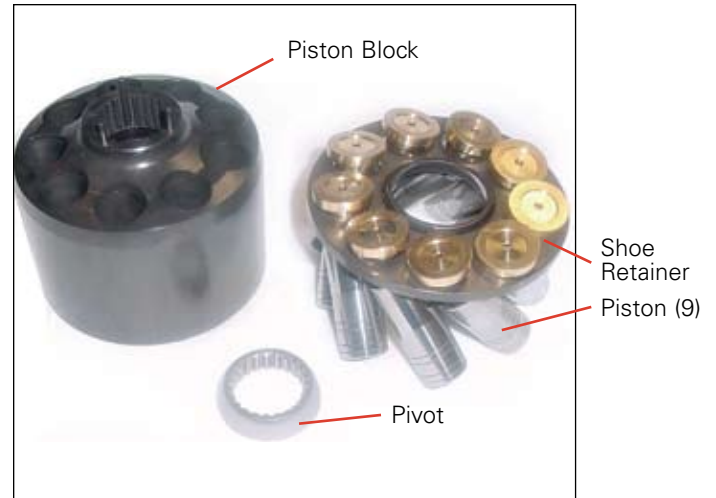

Note: Do not lap the face of piston block assembly.

Piston S/A Tolerances

This dimension must be maintained on all nine shoes within 0.001 inch.

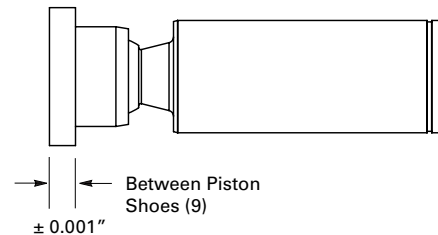

Shoe face rides on swash plate. Shoe must swivel smoothly on ball.
End play must not exceed 0.005 inch.

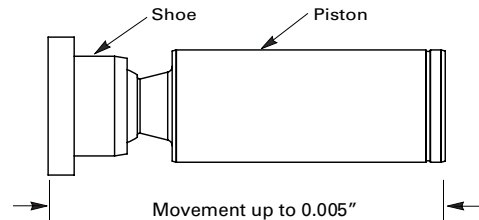

Inspection, Repair and Part Replacement

End Cover & Associated Parts

1. Inspect end cover for erosion, cracks, and burrs. Clean up minor burrs with an India stone. If erosion or cracks are found, replace the valve block.
2. Inspect roller bearing and bearing race for nicks and pitting. Make sure the roller bearing turns freely within the bearing race. If the roller bearing needs replacement, both the roller bearing and the bearing race must be replaced.
3. Inspect valve plate for erosion, excessive wear, heavy scratches, and cracks. If any of the above conditions are found, replace the valve plate.
4. Inspect control piston and maximum displacement screw for burrs, scratches and cracks. Clean up minor scratches with 500 grit paper. Remove burrs with an India stone. The control piston should move freely in the bore.

Swashplate Parts

1. Inspect swashplate face for wear, roughness or scoring. Check the swashplate hubs and bearing surfaces for wear and cracks. Replace if defective.
2. Inspect saddle bearing surfaces for wear, pitting, and smooth operation. Replace if necessary.

Shaft/Housing Parts

1. Inspect drive shaft for wear, stripped splines, and burrs. Remove burrs with an India stone. Inspect the contact area of bearing and shaft seal). Replace the drive shaft if wear or scoring is greater than 0.005 T.I.R. (total indicator reading).
2. Inspect drive shaft bearing for roughness, pitting of rollers, and excessive end play. Replace, if defective. If the bearing needs to be replaced, the bearing race also requires replacement.
3. Inspect housing mounting flange for nicks and burrs. Remove minor nicks and burrs with an India stone. Also check the housing for damaged or stripped threads. If any thread is damaged, replace the housing.
4. Check remaining pump parts for excessive wear, damaged threads, burrs, cracks and erosion. Replace any part that is in questionable condition.

Inspection, Repair and Part Replacement

Shimming Process

Kit 9900194-008

Shimming Process Installation Information

This shim kit is to replace the crush ring within the pump housing. If the housing, drive shaft, shaft bearings or end cover is replaced during servicing, the original crush ring can no longer be used to assure proper bearing set.

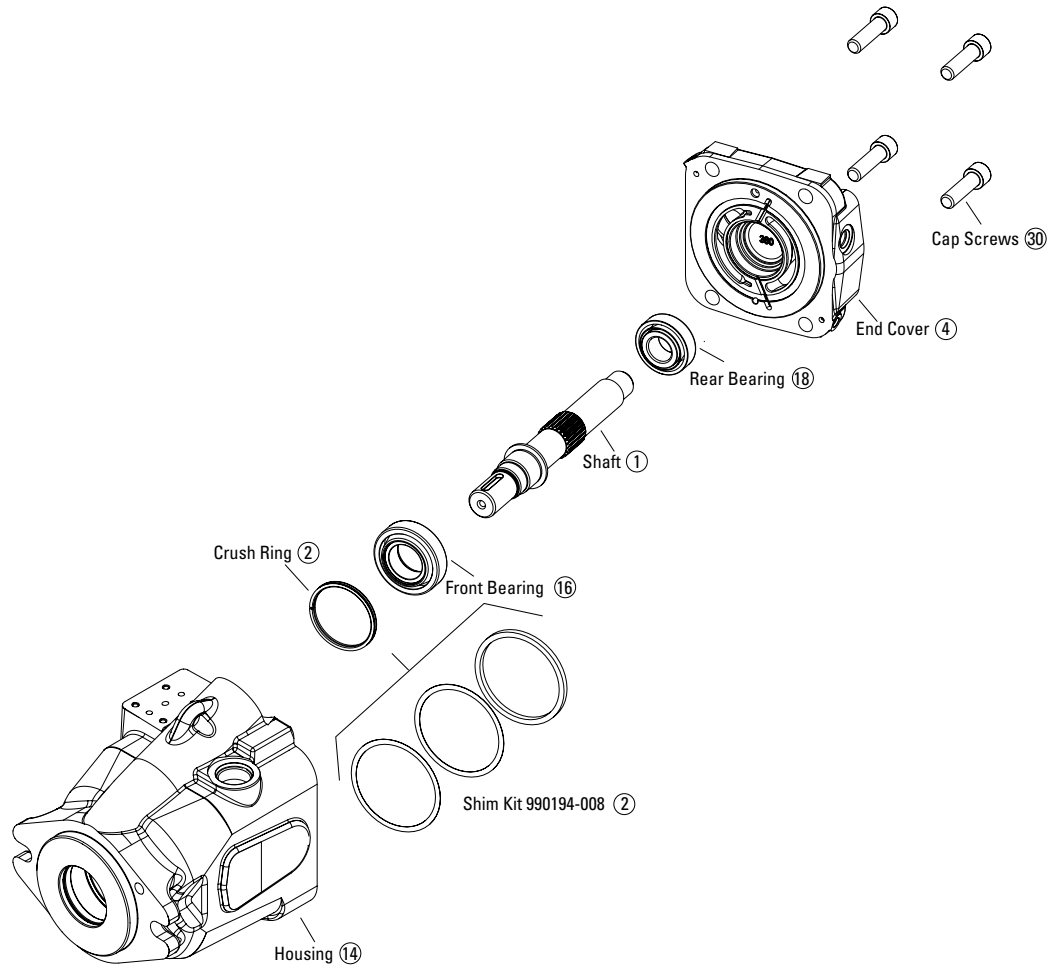

Shimming Procedures

1. Measure the thickness of the existing crush ring.
2. To obtain a starting point, stack shims to a few thousandths of an inch less than the measurement of existing crush ring. Then insert shims into the housing in the same location as the removed crush ring.
3. Assemble the housing (without interface O-ring seals), shaft bearings, shaft and end cover. Install the end cover cap screws and torque to 97+/- 9 lb-ft.
4. Using a dial indicator, measure drive shaft end play. Target bearing set range is .001" clearance to .002" interface (preload). Add shims to achieve proper bearing set. If no movement of the shaft is observed, shims will need to be removed and steps 3 and 4 repeated.
5. Finish the assembly of the pump.



Assembly

Assembly must be conducted in a clean environment. Dispose of leakage oil and oily cloths in an environmentally responsible manner. Before assembly carefully clean all

parts and blow out holes with compressed air. Tighten all screws/plugs to the specified torque (see Appendix A). Exceptions are specified in the text. Lubricate O-rings and

shaft sealing rings lightly with acid free lubricant for easier installation and to hold the O-ring in place in its groove or cavity.

1. Install Snap Ring and Shaft Seal



3. Insert the Shaft Bearing Race



2. Install Crush Ring



4. Install Cradle Bearings



Note: The cradle bearings are asymmetrical. Install as shown in picture.

5. Install Cradle Bearing Screws



Note: The old cap screws cannot be reused and must be replaced with new ones because the screws will be damaged during disassembly. The new cap screw threads will be coated with loctite.

Kit #9900194-002 (2) bearings and (2) screws per kit.

6. Install Bearing



7. Install Bias Spring

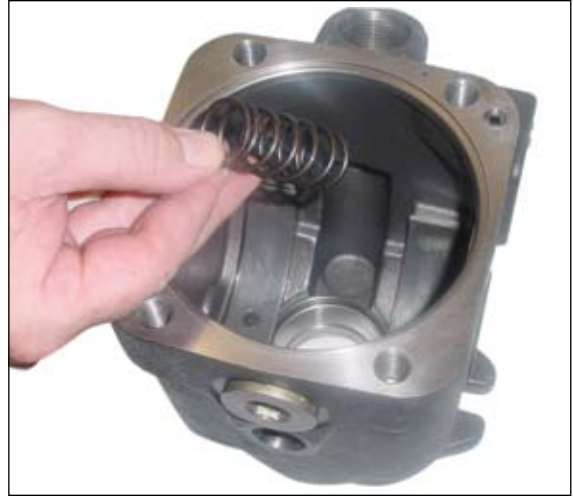

8. Install Swashplate



Note: With the bias spring in place, tilt the swash plate toward the spring and install the swash plate.

9. Install Control Piston



11. Install Swashplate Locator



Note: Adjust the screw until the swashplate is near neutral (will look flat in housing).

10. Install Swashplate Retainer



12. Install Shaft



Caution: Use care while inserting shaft end through shaft seal.

13. Install Shaft Retainer Tool



15. Remove Swashplate Locator



14. Install the Rotating Group



Note: Position shaft upwards and carefully install rotating group.

16. Remove Swashplate Retainer

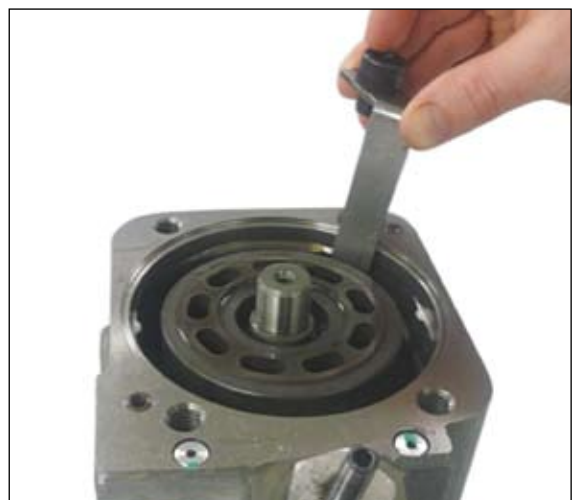

17. Install O-ring Seal



19. Install Bearing Race

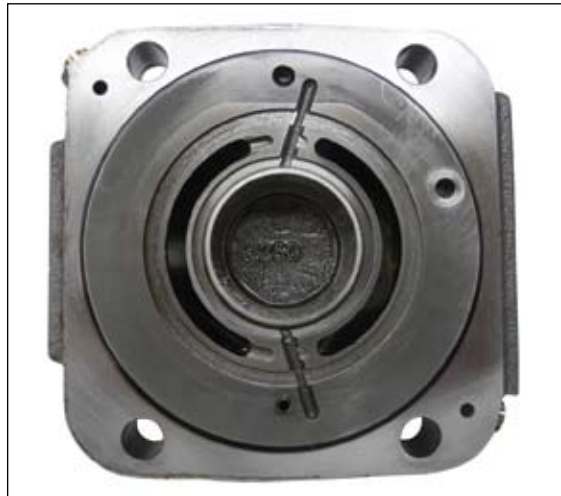

Note: Using a press, install the bearing race.

18. Install Housing O-rings



20. Install Valve Plate

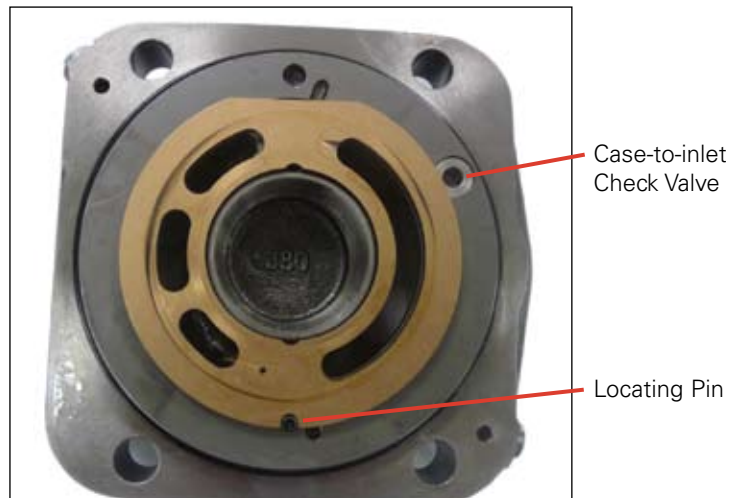

Note: Lightly coat the back plate side of the valve plate with petroleum jelly for retention during assembly.

Install the valve plate over the bearing race aligning the small slot on the outside of the valve plate with the dowel pin in the back plate.

21. Install Bearing



22. Install End Cover



Note: Ensure correct orientation. Use caution so valve plate does not fall off.

23. Install Control Piston Plug Assembly



24. Install Compensator



25. Testing

Perform functional test on pump according to Eaton test procedure. Contact your area sales manager for more information.

Assembly Torque Values

Instructions

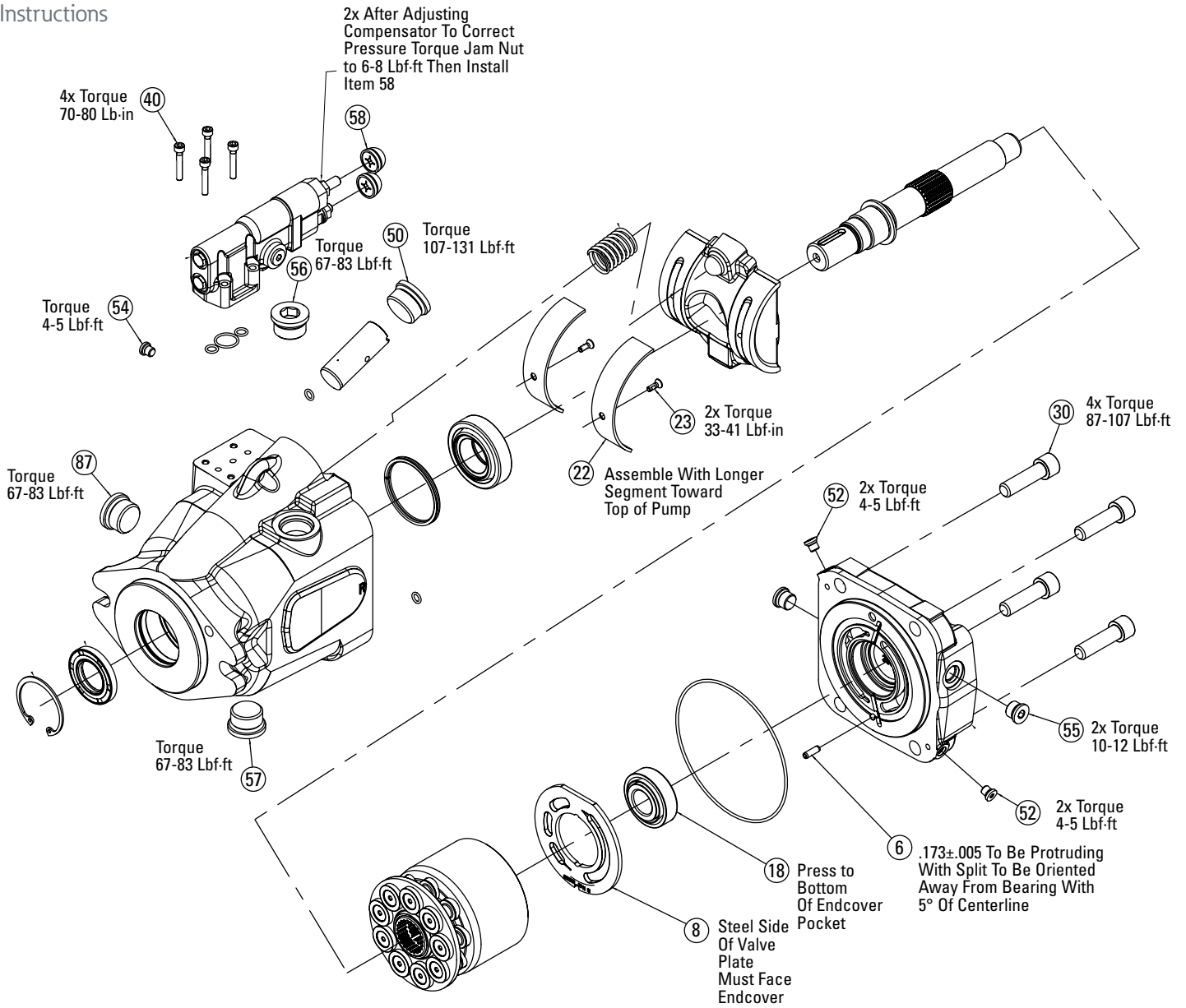

Thru-Drive Part Option

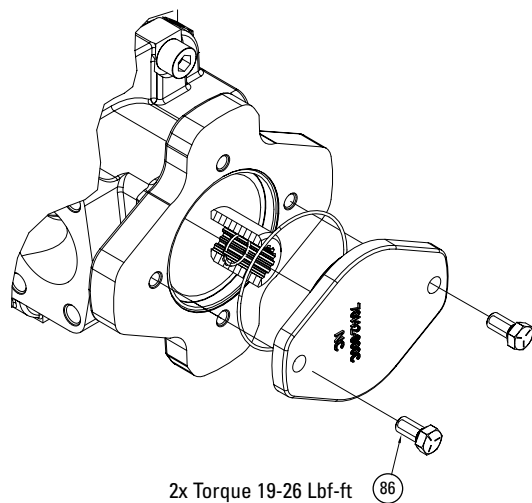

Dual Shaft Seal Option

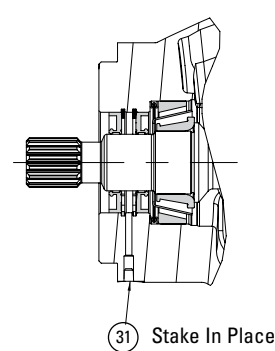

Adjustable Maximum Stop Option

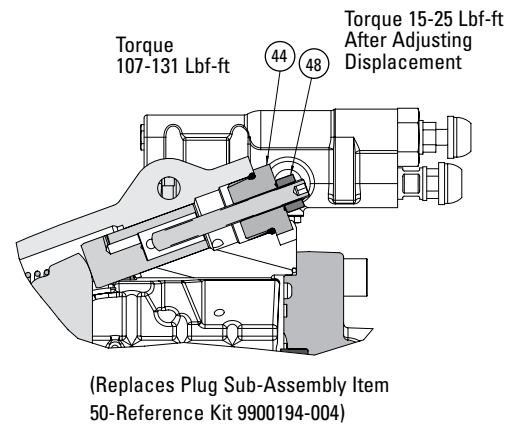

Eaton
Hydraulics Group USA
14615 Lone Oak Road
Eden Prairie, MN 55344
USA
Tel: 952-937-9800
Fax: 952-294-7722
www.eaton.com/hydraulics

Eaton
Hydraulics Group Europe
Route de la Longeraie 7
1110 Morges
Switzerland
Tel: +41 (0) 21 811 4600
Fax: +41 (0) 21 811 4601

Eaton
Hydraulics Group Asia Pacific
Eaton Building
4th Floor, No. 3 Lane 280 Linhong Rd.
Changning District
Shanghai 200335
China
Tel: (+86 21) 5200 0099
Fax: (+86 21) 5200 0400



Powering Business Worldwide

© 2009 Eaton Corporation
All Rights Reserved
Printed in USA
Document No. E-PUPI-TP002-E3
Supersedes E-PUPI-TP002-E2
August 2009